

# ZAZA2 SWIVEL

## 4 WAYS ROTATING SWITCHING PLATE

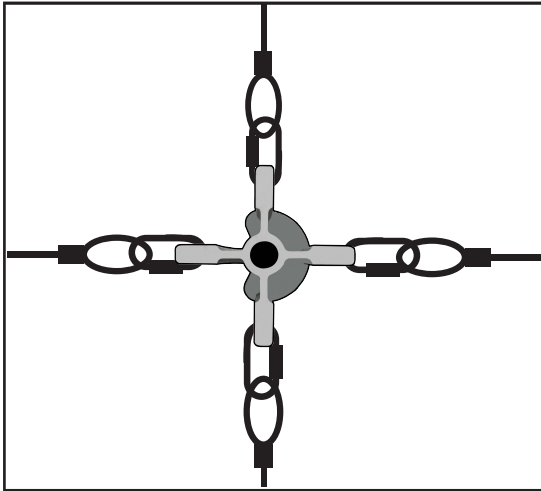

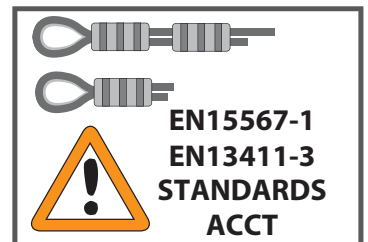
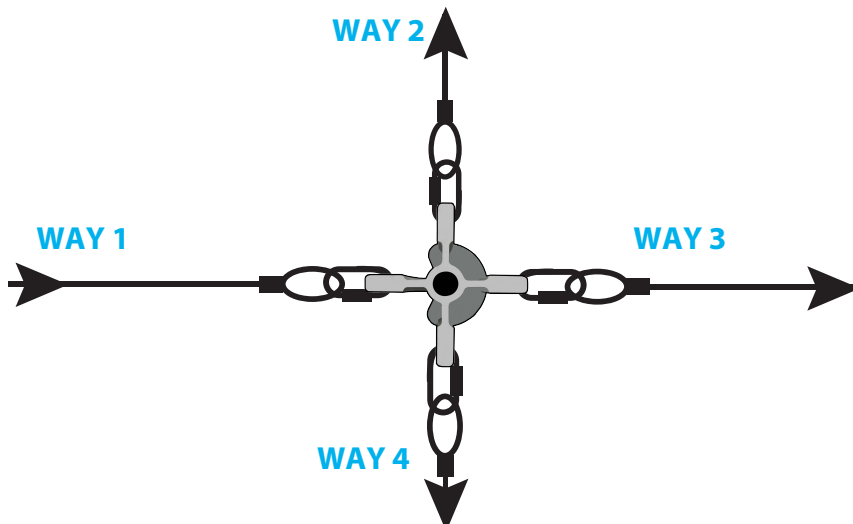
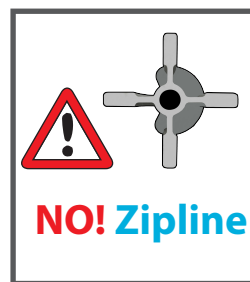
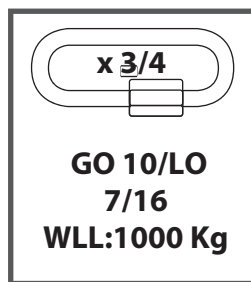
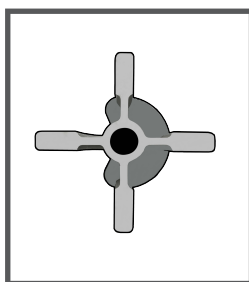
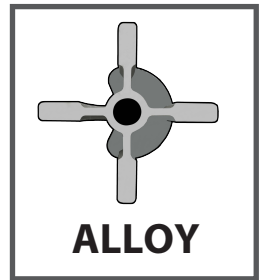
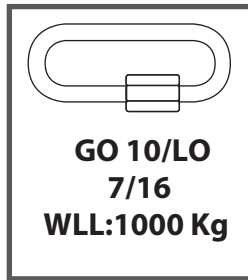
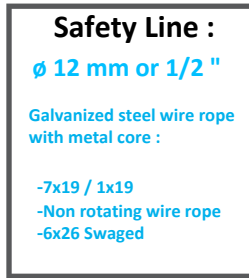

### ADVANTAGES

- Escape
- Diversion
- Overtaking

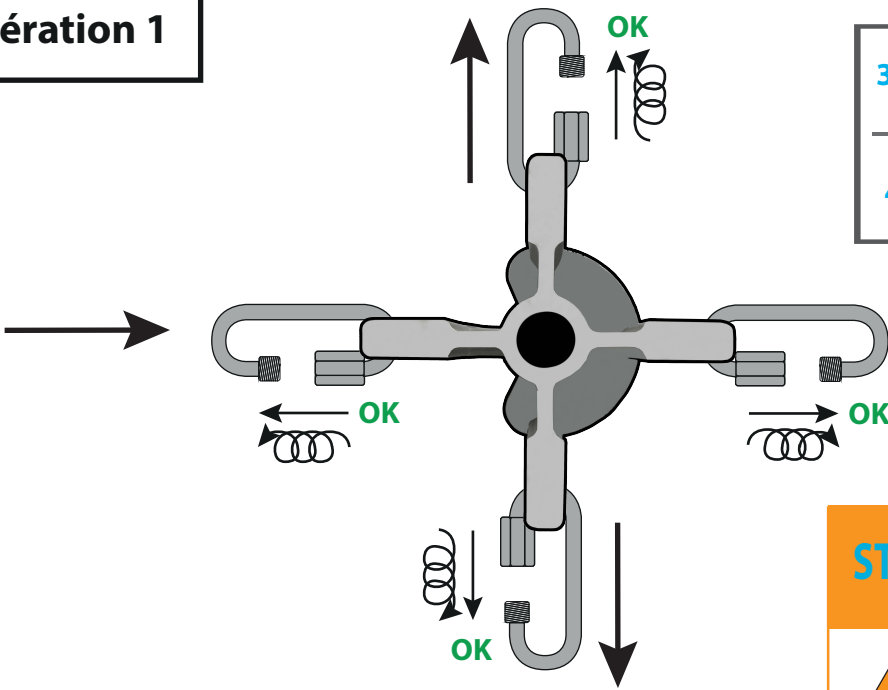

# Opération 1



3WAYS = 3 X  + 

---

4WAYS = 4 X 

**STANDARDS OF ASSEMBLY**

 EN 15567-1  
EN13411-1/7  
STANDARDS -ACCT

# Opération 2

## ASSEMBLY COMBINATION NON CONTRACTUAL EXAMPLE

### ● EXAMPLE 1 : 4 WAYS

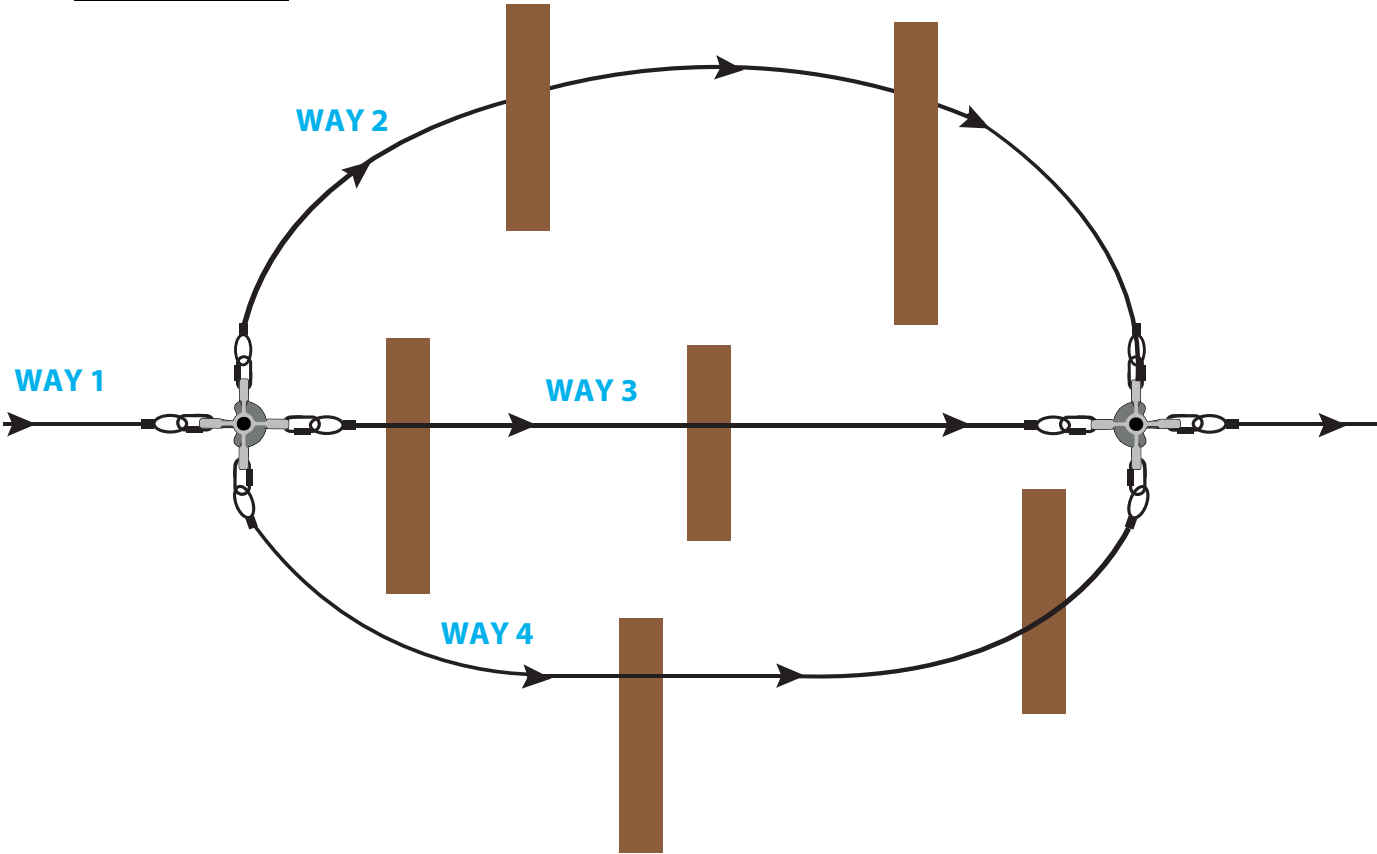

● **EXAMPLE 2: 4 WAYS**

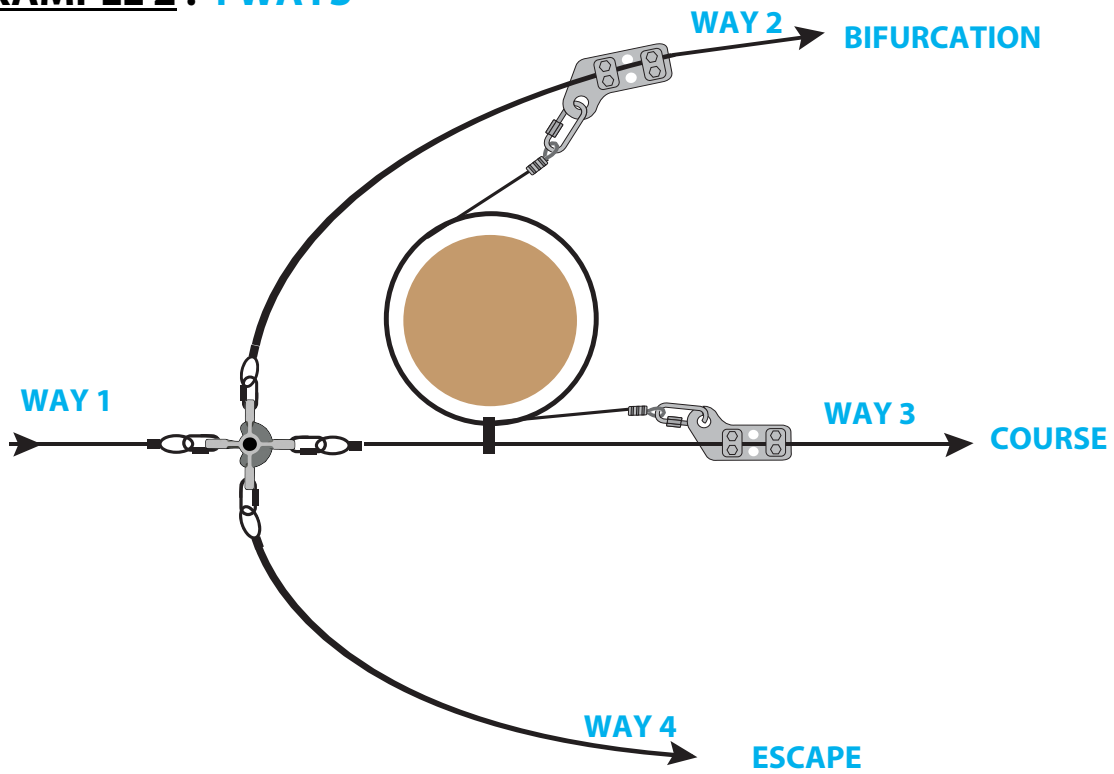

● **EXAMPLE 3: 3 WAYS**



**CONDEMN THE FOURTH WAY**

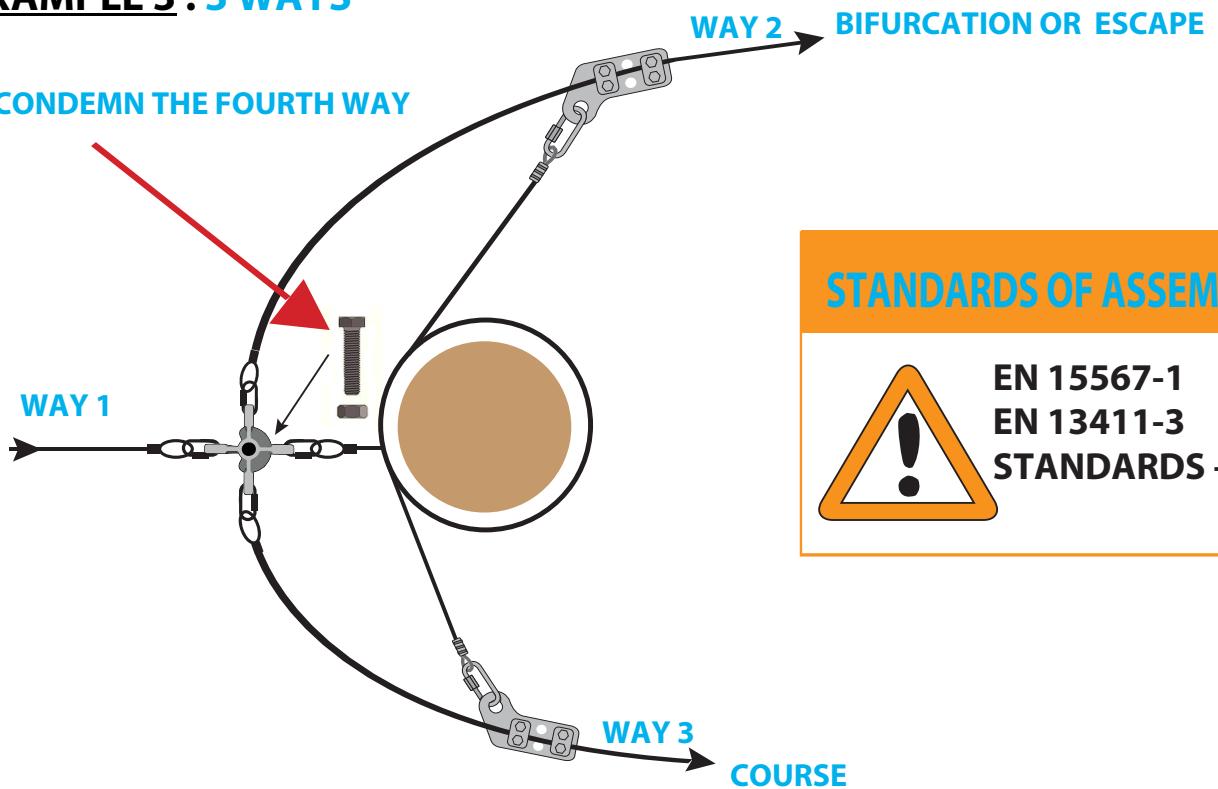

**STANDARDS OF ASSEMBLY**



EN 15567-1  
EN 13411-3  
STANDARDS - ACCT

● **EXAMPLE 4 : 3 WAYS OVERTAKING**

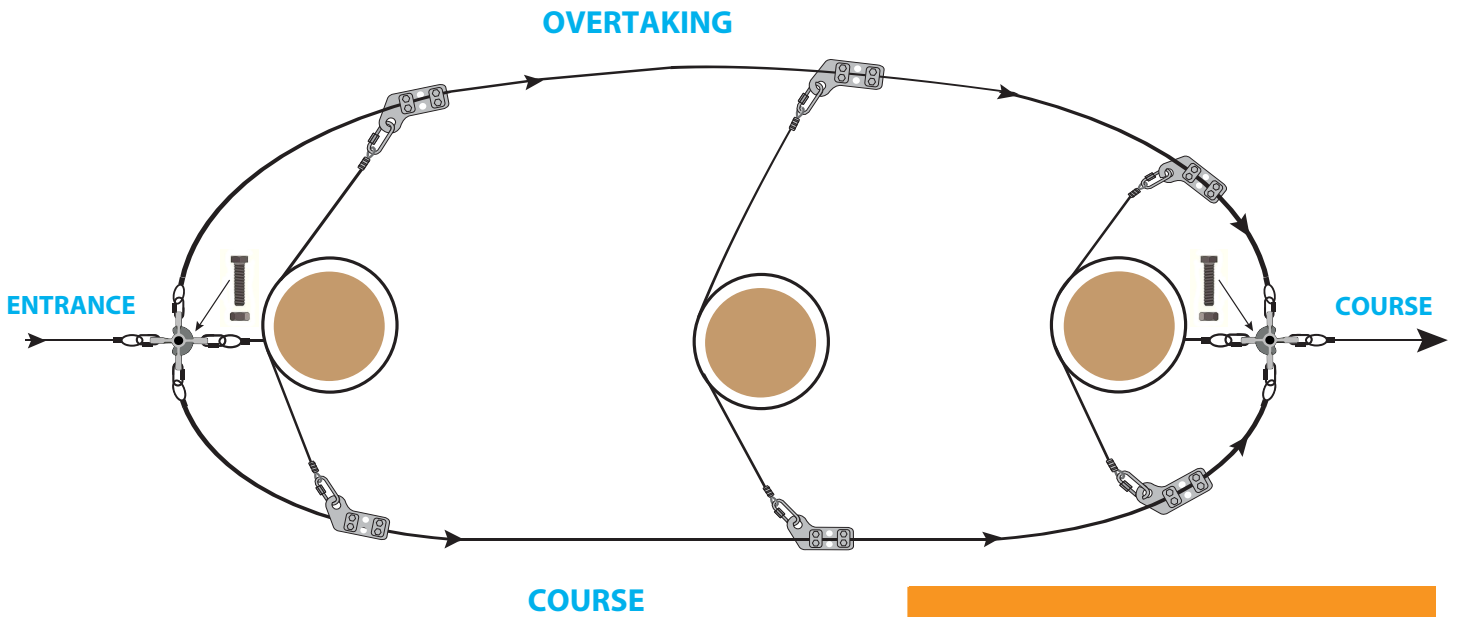

**STANDARDS OF ASSEMBLY**



EN 15567-1  
EN 13411-3  
STANDARDS - ACCT

**Opération 3**

**RECOMMENDATIONS OF ASSEMBLY**



**FLEXIBLE ASSEMBLY**

