

# ZAZA 2 DOUBLE DELTA

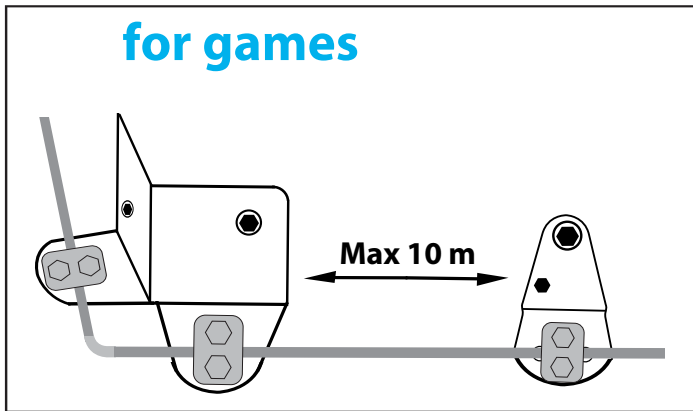

### ADVANTAGES:

- SPECIAL FOR ARTIFICIAL STRUCTURE
- REALIZE BENDS OF 90°
- FLEXIBILITY

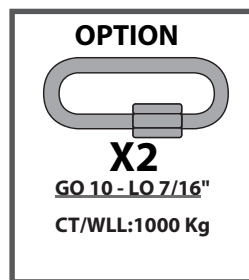
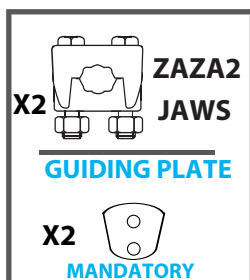
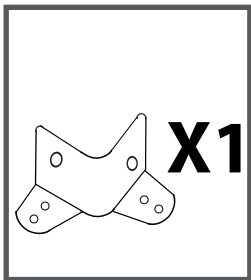
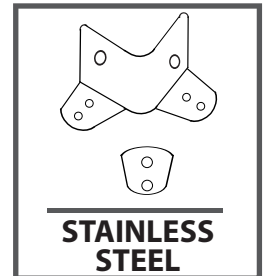
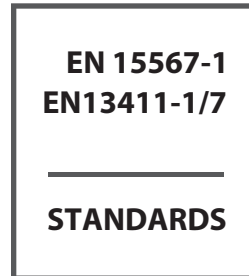
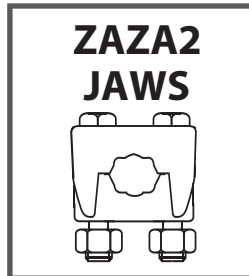
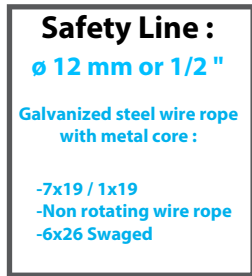

### EXAMPLE OF FIXING SYSTEM

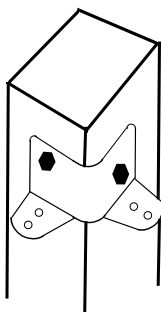

**WLL of the fixing element must be correctly sized**

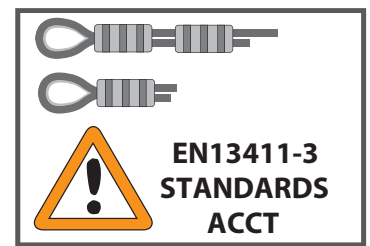

# Opération 1

# RECOMMANDATION OF ASSEMBLY

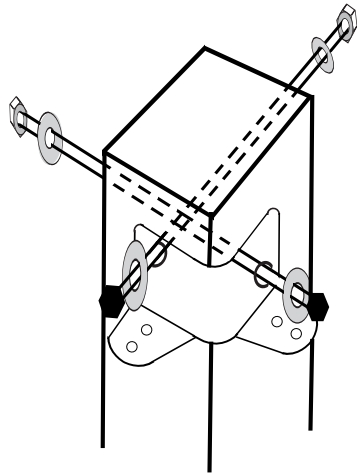

BOLT Ø 12mm  
HR-1/2" HS

THREADED ROD  
Ø 12mmHR  
1/2"HS



# Operation 2

# STARTING & ARRIVAL PLATE

## EXAMPLES:

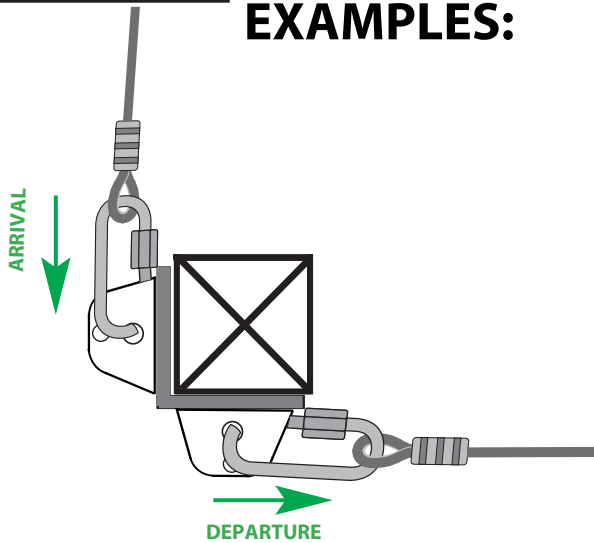

### STANDARDS OF ASSEMBLY



EN 15567-1  
EN 13411-1/7  
STANDARDS - ACCT

X2 MRGO10-LO 7/16"

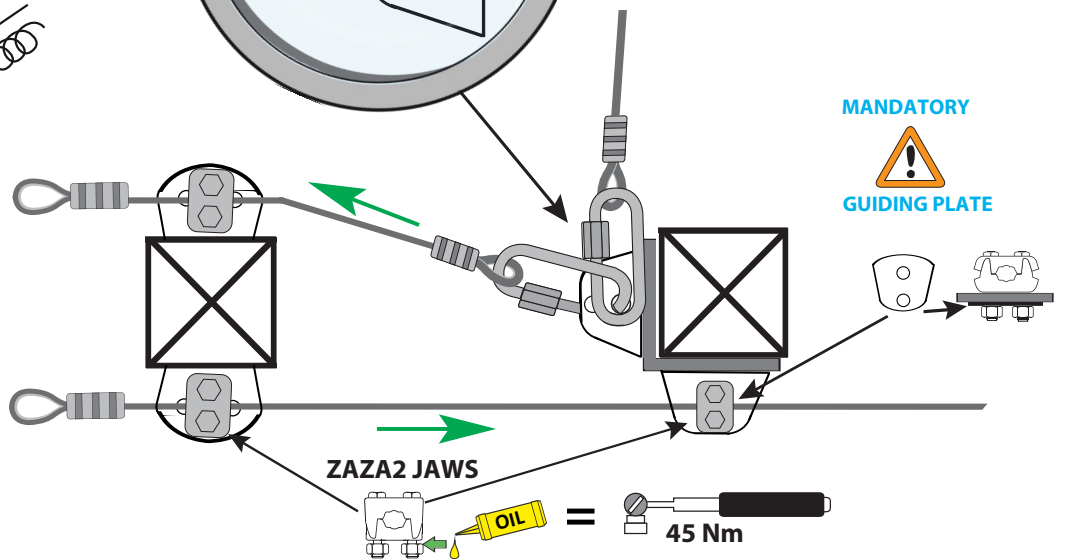
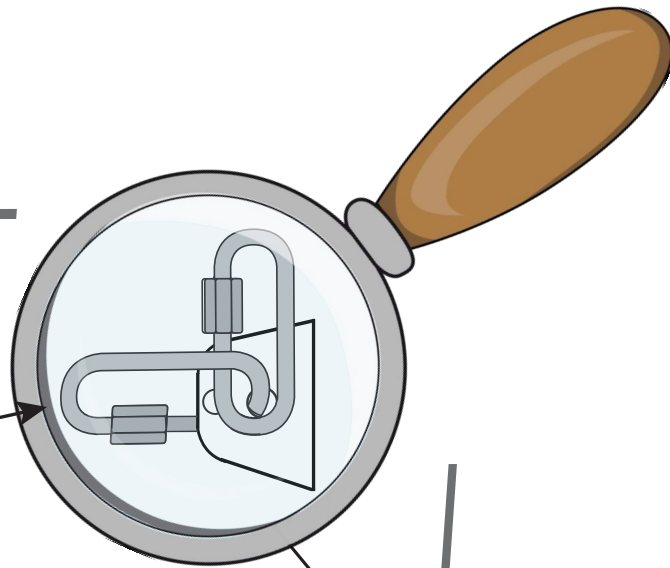

### Operation 3

## Examples of mounting Combination

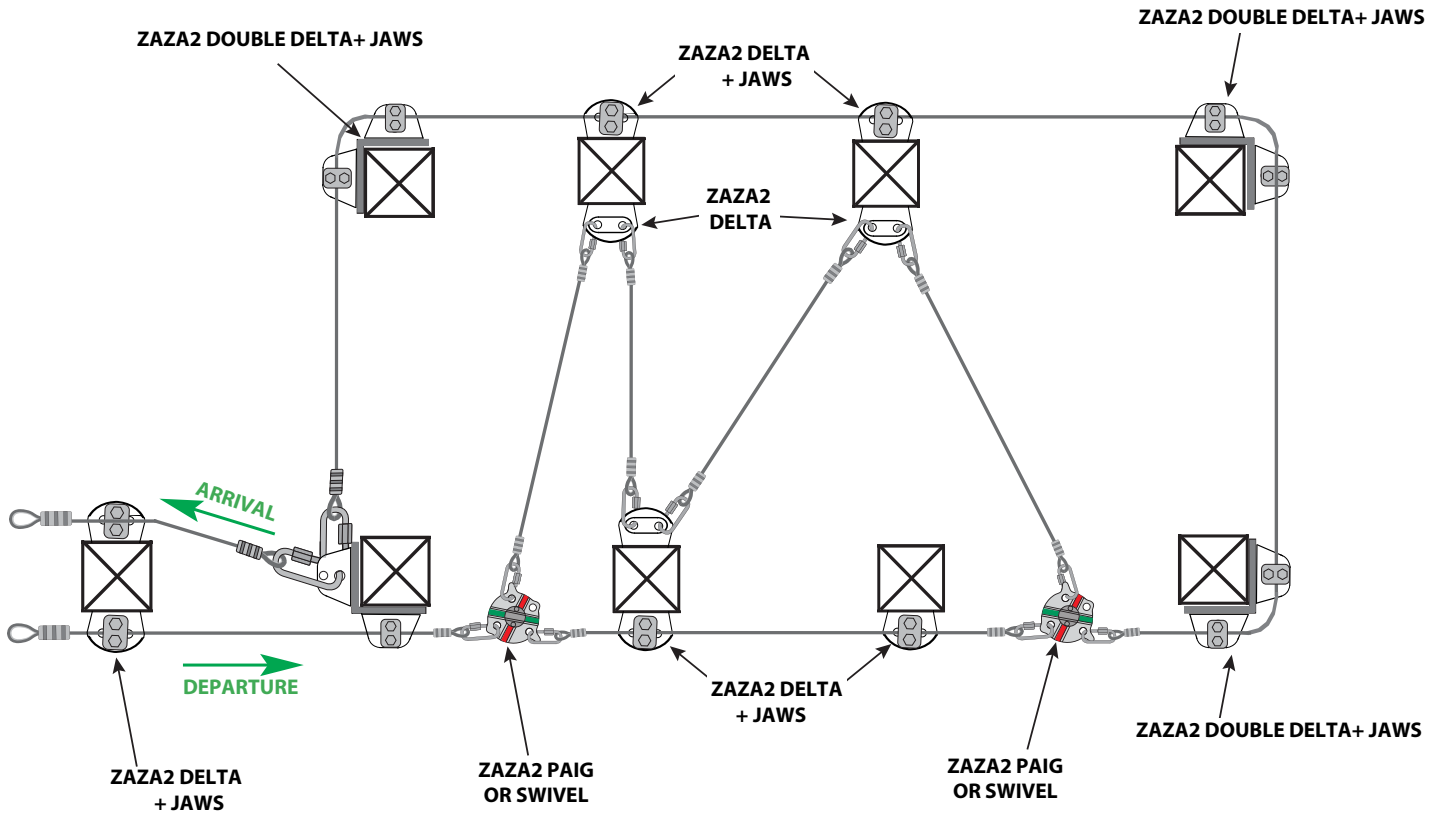

### Operation 4

## RECOMMANDATION OF ASSEMBLY

### STANDARDS OF ASSEMBLY



EN 15567-1  
EN 13411-1/7  
STANDARDS - ACCT

