

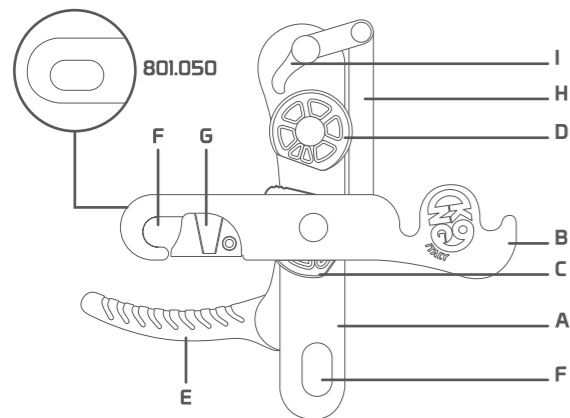



# NOMENCLATURE



**A** Fixed side plate | **B** Sliding side plate | **C** Lower pulley | **D** Upper pulley | **E** Control handle | **F** User/ anchor point attachment hole | **G** Safety lock (only 801.040 version) | **H** Rod | **I** Blocking tooth  
**Main materials:** stainless steel, aluminium alloy, nylon

**A** Guancia fissa | **B** Guancia mobile | **C** Puleggia inferiore | **D** Puleggia superiore | **E** Leva di azionamento | **F** Punto di attacco per l'utilizzatore/l'ancoraggio | **G** Chiusura di sicurezza (solo versione 801.040) | **H** Barra | **I** Dente di bloccaggio  
**Materiali principali:** acciaio inossidabile, lega di alluminio, nylon

**A** Joue fixe | **B** Joue mobile | **C** Poulie inférieure | **D** Poulie supérieure | **E** Levier d'actionnement | **F** Trou de connexion pour l'utilisateur/l'ancrage | **G** Fermeture de sécurité (version 801.040 seulement) | **H** Tige | **I** Dent de blocage  
**Matériaux principaux :** acier inoxydable, alliage d'aluminium, nylon

**A** Festes Seitenteil | **B** Bewegliches Seitenteil | **C** Untere Riemenscheibe | **D** Obere Riemenscheibe | **E** Antriebshebel | **F** Verbindungsöse für den Benutzer/die Verankerung | **G** Sicherheitssperre (nur Version 801.040) | **H** Stange | **I** Blockierzahn  
**Hauptmaterialien:** Edelstahl, Aluminiumlegierung, Nylon

**A** Placa fija | **B** Placa móvil | **C** Polea inferior | **D** Polea superior | **E** Palanca de accionamiento | **F** Punto de enganche para el usuario/ancraje | **G** Bloqueo de seguridad (sólo versión 801.040) | **H** Varilla | **I** Diente de bloqueo  
**Materiales principales:** acero inoxidable, aleación de aluminio, nylon

**A** Фиксированная губка | **B** Подвижная губка | **C** Нижний шкив | **D** Верхний шкив | **E** Рычаг управления | **F** Точка крепления для пользователя/фиксации | **G** Предохранительный замок (только версия 801.040) | **H** Бар | **I** Запирающий зуб  
**Основные материалы:** нержавеющей сталь, алюминиевый сплав, нейлон



# 801.040 - 801.050 INDY EVO PLUS

EN 12841 USE

WWW.KONG.IT



**Read and always follow the information supplied by the manufacturer**  
 Leggere e seguire sempre le informazioni fornite dal fabbricante  
 Toujours lire et suivre les informations fournies par le fabricant  
 Die Angaben des Herstellers müssen immer gelesen und befolgt werden  
 Lea siempre y respete la información proporcionada por el fabricante  
 Читайте и всегда следуйте информации, предоставленной производителем



**Download the declaration of conformity at:**  
 Scarica la dichiarazione di conformità da:  
 Téléchargez la déclaration de conformité sur:  
 Laden Sie die Konformitätserklärung herunter von:  
 Descargar la declaración de conformidad en:  
 Загрузить заявление о соответствии:  
[www.kong.it/conformity](http://www.kong.it/conformity)



**Please calculate the lifespan of the device according to:**  
 Calcola la vita utile del dispositivo in accordo a:  
 Calculez la durée de vie de le dispositif selon:  
 Berechnen Sie die Lebensdauer der Vorrichtung nach:  
 Calcular la vida útil del dispositivo según:  
 Пожалуйста, рассчитайте срок службы устройства в соответствии с:  
[www.kong.it/en/life/](http://www.kong.it/en/life/)

Y5451000BFK

KONG S.p.A. - Via XXV Aprile, 4 23804 Monte Marenzo (LC) - Italy  
 +39 0341 630506 | info@kong.it

# SPECIFIC INFORMATION

Master Text

Category III Personal Protective Equipment 801.040 - 801.050 INDY EVO PLUS is:  
 - a manually operated, friction inducing rope adjustment device which allows the user to achieve a controlled downward motion at a maximum speed of 2 m/s and a stop, with hands off, anywhere on the working line;  
 - suitable for use on a semi-static rope (EN 1891/A) with a diameter between Ø10 mm and Ø12 mm for a maximum rated load of 100 kg;  
 - suitable for use on a semi-static rope (EN 1891/A) with a diameter between Ø11 mm and Ø12 mm for a maximum rated load of 200 kg;  
 - intended always to be used in conjunction with rope adjustment device compliant with EN 12841:06 type A and/or EN 353:02 connected to a safety line;  
 - part of a protection and/or prevention system against falls from a height, in rope access systems;  
 - certified according to EN 12841:2006 type C.  
 Attention: the use by two people (possible according to EN 12841:06) is not recommended, as it contradicts the definition of PPE (Personal Protective Equipment).

### How to insert the line into the device (fig. 1)

- open the device by turning the sliding side plate (B) clockwise;
- insert a connector conforming to EN 362 into the attachment hole (F) of the fixed side plate (A);
- hold the lever (E) open;
- wrap the unloaded end of the rope around the lower pulley (C);
- insert the unloaded end of the rope between the tooth (I) and the upper pulley (D);
- close the sliding side plate (B) by turning it anti-clockwise, locking the attachment holes (F);
- check that the safety lock (G) is free from the connector.

### How the mechanism works

Pull the lever to start the descent (fig. 2).  
 Release the lever to stop the descent (fig. 3).  
 The tooth (I) and its mechanism are designed to reduce involuntary and uncontrolled descent.

### Descent with the device connected to the harness (fig. 4)

- connect one end of the line to the anchor (EN 795);
- insert the rope into the device as described;
- connect the connector to the harness attachment point;
- tighten the part of the rope between the device and the anchor;
- keep the unloaded end of the rope taut, to prevent initial slippage;
- move the lever (E) and act on the free end of the line until the desired descent speed is reached (max. 2 m/s).

**Important:** the anchor point must comply with EN 795 and always be above the user. The rope between the anchor and the device must always be taut.

### Examples of correct use

- Extra friction (fig. 5): it is possible to achieve more control of the descent and further limit the speed using this type of configuration.
- Releasable anchor (fig. 6): this modality helps to get more rope when needed (for this type of use, the device is not considered PPE).

### Compatibility

- This device is designed to be used with:
- ropes with a diameter between 10 mm and 12 mm according to EN 1891/A;
  - connectors according to EN 362;
  - harnesses according to EN 813;
  - anchor devices according to EN 795.

### Warning

- the primary function of this device is progression along the working line; therefore, it is not suitable to be used in a fall arrest system and it must always be used in conjunction with a rope adjustment device conforming to EN 12841 type A and/or EN 353-2 connected to a safety line (fig. 7);
- incorrect insertion or connection of the line (e.g. the free end on the lever side) nullifies the performance of the device (fig. 8);
- when descending, always grasp the unloaded end of the rope with your right hand to maintain control (fig. 9);
- carefully choose the correct anchor line according to the recommendations given in this manual; construction and surface treatment of the sheath, as well as the diameter of the line, are factors not to be underestimated in the selection and may affect the performance of the system;
- when the anchor line is loaded by the full weight of the user, it becomes a working line. The additional use of a safety line is therefore necessary;
- there are no limitations on the inclination of the anchor line. However, to prevent the pendulum effect, it is advisable to work as vertically as possible with the anchor point;
- connect the device to the harness with systems with a maximum length of 1 metre;
- particular conditions (e.g. heat, cold, wet, oil and dust etc.) can greatly limit the performance and operation of the device;
- the device can be severely damaged if in contact with chemical reagents. It should be withdrawn immediately if its safe functioning is in any doubt;
- any overload or dynamic loading on the device may damage the anchor line.

### Pre- and post-use checks

- Before and after use, make sure that the device is in an efficient condition and that it is working properly, in particular, check that:
- it is suitable for the intended use;
  - it is free of cracks, corrosion, mechanical deformation and that any wear and tear is only of an aesthetic nature;
  - the sliding side plate (B) can rotate, the lever (E) activates the pulley (C), the rod (H) and the tooth (I), and the safety lock (G) closes automatically when released;
  - the rope passage area is free of foreign elements (stones, sand, mud, lubricants, etc.);
  - the markings are legible.

### Certification

This device has been certified by the notified body n° 0123 TÜV SÜD Product Service GmbH Daimlerstraße 11 - 85748 Garching - Germany

# DRAWINGS

